

AquaMatic® Easy Nest Kit



The AquaMatic Easy Nest Kit outperforms large multipoint valves in many ways: greater application flexibility, improved flow rate performance and significant cost savings. Pentair Water® makes it easy to specify, quote and build a superior system. Our Easy Nest Kits simplify a valve nest down to only two part numbers (valving and stager controller). Now all you need to do is determine the tank size, flow rate and piping size. At the heart of the system is the industry-proven AquaMatic Diaphragm Valve, first introduced over 45 years ago.

Open the door to a whole new spectrum of tank sizes you may have never tried before. AquaMatic Valves and Controls Easy Nest Kits give you opportunities to seek new business that will result in a new level of success.



AquaMatic® Easy Nest Kit



Valve Body Features

- **Cast Iron**
 - Requires threaded/flanged piping
 - Requires union connectors
 - Susceptible to corrosive water
- **K52 (Composite)**
 - Solvent weld
 - Requires union connectors
 - Corrosion resistant
- **K53 (Composite)**
 - Solvent weld
 - No union connectors needed*
 - Corrosion resistant

Control Features

- **Electromechanical Controllers** – Regenerates based on a set time
- **Electronic (Metered/Signal) Controllers** – Regenerates based on a set time, metered water usage or external signal

* Drawings on pages 6 and 7 show union connectors as part of the installation. When using the K53 valves, those union connectors are not necessary.

Selecting the Appropriate Stager and Nest Kits

Selection of the stager and valve nest kit can be done with two part numbers. The part numbers for the staggers can be found on page 4 of this specification sheet. The valve nest kit part numbers

can be found on page 3 (softeners) and page 4 (filters). Backwash flow controls, brine valves, and water meters are not included as part of the Easy Nest Kits and must be ordered separately. Below

are brief descriptions of the staggers and valves. A raw water bypass option for single tank units is available, but a normally closed valve must be ordered separately.

Selection Process

CONTROL CHOICES EXAMPLE (PAGE 4):

Select electronic or electromechanical	Electronic
Select the correct option for your application	2 Tank Alternating Softener
Find part number	1078842
Select quantity of controllers	1

VALVE NEST CHOICES EXAMPLE (PAGE 3 OR 4):

Select filter or softener	Softener
Select valve type (Cast iron, K52, K53)	K53 Valve Series
Select size of system based on tank diameter, pipe size, or flow rate	54" Tanks
Find part number	1078803
Select quantity of nest kits	2 (Alternating)

SAMPLE ORDER

QTY.	PN	DESCRIPTION
1	1078842	2 Tank Alternating Softener Controller
2	1078803	S537-54 Nest Kit



Performance Range (Single Tank Systems)

Service Flow Rates	80 to 1300 gpm (18 to 295 m ³ /h) per tank
Backwash Flow Rates (Softeners)	35 to 392 gpm (8 to 89 m ³ /h)
Backwash Flow Rates (Filters)	35 to 1200 gpm (18 to 272 m ³ /h)
System Sizes	36- to 120-inch Diameter Tanks

Configurations

SYSTEM CONFIGURATIONS	
Softeners	
Single Tank	4 Position
Multi-Tank	2, 3, and 4 Tank, Parallel; 2 Tank Alternating Softeners
Filters	
Single Tank	3 Position
Multi-Tank	2, 3, and 4 Tank, Sequential
CONTROL CONFIGURATIONS	
Electronic	
Programmable Regeneration Range	Demand and Time Clock (Battery Back-up) 0-255 Minutes Regeneration (Each Cycle)
Electromechanical	
Programmable Regeneration Range	Time Clock, 6 or 7 Day 3-102 Minutes Complete Regeneration Cycle
Stager Valves	
	6, 8 and 16 Ports
PIPING CONFIGURATIONS	
Valves	
Cast Iron	3/4- to 3-inch Female Thread, NPT, BSP, JIS; 3- to 6-inch Flanged
Noryl (Plastic)	1- to 3-inch Union, Female Solvent Weld; 2- to- 3 inch Female Solvent Weld or Flange
Injectors	1/2- to 2-inch Female NPT Thread, Solvent Weld
Stager Tubing	1/4-inch Poly Tubing

Operating Specifications

Valve Body	Cast Iron or Glass-filled Noryl
Diaphragm	Buna N/Polyamide
Injector	PVC
Control Enclosures (Electromechanical)	NEMA 1
Control Enclosures (Electronic)	NEMA 4X Fiberglass
Operating Pressure	20 to 120 psi (1.38 to 8.27 bar)
Operating Temperature	35° to 120°F (2° to 38°C)
Operating Voltages	115V, 50/60 Hz; 220V, 50/60 Hz

AquaMatic® Easy Nest Kit

Available Standard Softener Configurations

Model Number	Part Number	Tank Diameter Inches (cm)	Resin Amount Cu. Ft. (liters)	Pipe Size Inches	Service Flowrate at Pressure Drop		Backwash Flowrate at Pressure Drop	
					GPM @ PSI	(m ³ /hr @ bars)	GPM @ PSI	(m ³ /hr @ bars)
Cast Iron Valves								
S425-36	1078826	36 (92)	20 (565)	2	100 @ 6.4	(22.7 @ .44)	36 @ 2.3	(8.1 @ .16)
S425-42	1078783	42 (106)	30 (850)	2	150 @ 14.3	(34 @ .98)	48 @ 4.4	(10.9 @ .30)
S426-48	1078784	48 (120)	40 (1130)	2	180 @ 14	(40.9 @ .96)	63 @ 7.5	(14.3 @ .51)
S426-54	1078785	54 (135)	50 (1415)	2-1/2	220 @ 13.7	(50 @ .94)	80 @ 12.2	(18 @ .84)
S427-60	1078786	60 (150)	60 (1700)	3	300 @ 10.0	(68 @ .69)	98 @ 6.3	(22.2 @ .43)
S427-63	1078828	63 (160)	70 (1980)	3	325 @ 11.6	(73.8 @ .80)	108 @ 7.5	(24.5 @ .51)
S428-72	1078787	72 (180)	85 (2400)	4	425 @ 4.8	(96.6 @ .33)	140 @ 8.5	(31.8 @ .58)
S428-78	1078788	78 (200)	100 (2830)	4	500 @ 6.6	(113.6 @ .45)	165 @ 11.8	(37.5 @ .81)
S428-84	1078789	84 (215)	125 (3540)	4	625 @ 10	(142 @ .69)	192 @ 10.5	(43.6 @ .72)
S428-90	1078790	90 (230)	140 (3965)	4	700 @ 13	(159 @ .89)	220 @ 13.8	(50 @ .95)
S429-96	1078791	96 (245)	165 (4670)	6	825 @ 4.0	(187.5 @ .27)	255 @ 7.6	(58 @ .52)
S429-102	1078792	102 (260)	185 (5240)	6	925 @ 4.2	(210 @ .29)	285 @ 9.2	(64.7 @ .63)
S429-108	1078793	108 (275)	210 (5945)	6	1100 @ 6.0	(250 @ .41)	320 @ 11.5	(72.7 @ .79)
S429-114	1078794	114 (290)	235 (6655)	6	1200 @ 7.0	(272 @ .48)	355 @ 3.5	(80.6 @ .24)
S429-120	1078795	120 (305)	260 (7360)	6	1300 @ 8.3	(295 @ .57)	390 @ 5.0	(88.6 @ .34)
Composite Valves Series K52								
S524-36	1078796	36 (92)	20 (565)	1-1/2	80 @ 9.0	(18.1 @ .62)	35 @ 11	(7.9 @ .76)
S526-42	1078797	42 (106)	30 (850)	2-1/2	150 @ 4.5	(34 @ .31)	48 @ 4.0	(10.9 @ .27)
S526-48	1078798	48 (120)	40 (1130)	2-1/2	180 @ 7.0	(41 @ .48)	63 @ 5.6	(14.3 @ .38)
S526-54	1078799	54 (135)	50 (1415)	2-1/2	220 @ 10	(50 @ .69)	80 @ 10	(18 @ .69)
Composite Valves Series K53								
S534-36	1078800	36 (92)	20 (565)	1-1/2	100 @ 8.7	(22.7 @ .60)	35 @ 7.5	(7.9 @ .51)
S535-42	1078801	42 (106)	30 (850)	2	150 @ 6.4	(34 @ .44)	48 @ 2.0	(10.9 @ .14)
S535-48	1078802	48 (120)	40 (1130)	2	180 @ 9.2	(41 @ .63)	63 @ 4.0	(14.3 @ .27)
S537-54	1078803	54 (135)	50 (1415)	3	220 @ 2.4	(50 @ .16)	80 @ 7.0	(18 @ .48)
S537-60	1078829	60 (150)	60 (1700)	3	300 @ 4.5	(68.1 @ .31)	98 @ 8.4	(22.2 @ .57)
S537-63	1078804	63 (160)	65 (1840)	3	325 @ 5.3	(73.8 @ .36)	110 @ 4.0	(25 @ .27)
S537-72	1078805	72 (182)	90 (2550)	3	425 @ 9.0	(96.6 @ .62)	140 @ 7.0	(31.8 @ .48)

Note: Data supplied herein is provided as a guide only. Actual results may vary depending upon actual water conditions and system layout. Flow rates shown are valves only, not completed systems.



Available Standard Filter Configurations

Model Number	Part Number	Tank Diameter Inches (cm)	Pipe Size Inches	Service and Backwash Flowrate at Pressure Drop					
				5 GPM/Ft ² GPM @ PSI (m ³ /hr @ bars)		10 GPM/Ft ² GPM @ PSI (m ³ /hr @ bars)		15 GPM/Ft ² GPM @ PSI (m ³ /hr @ bars)	
Cast Iron Valves									
F425-42	1078806	42 (106)	2	48 @ 1.5	(10.9 @ .10)	96 @ 5.8	(21.8 @ .4)	145 @ 13.2	(33 @ .91)
F426-48	1078807	48 (120)	2	62 @ 1.7	(14 @ .11)	125 @ 6.7	(28 @ .46)	190 @ 15	(43.2 @ 1.03)
F426-54	1078808	54 (135)	2-1/2	80 @ 2.8	(18.1 @ .19)	160 @ 7.2	(36.2 @ .49)	240 @ 16	(54.5 @ 1.1)
F427-60	1078809	60 (150)	3	97 @ 1.1	(22.0 @ .07)	195 @ 4.3	(44 @ .29)	295 @ 9.5	(67 @ .65)
F428-72	1078810	72 (180)	4	140 @ 0.5	(31.8 @ .034)	280 @ 2.5	(63.6 @ .17)	425 @ 5.5	(96.6 @ .38)
F428-78	1078811	78 (200)	4	165 @ 0.7	(36.3 @ .048)	330 @ 3.2	(75 @ .22)	500 @ 7.5	(113 @ .51)
F428-84	1078812	84 (215)	4	190 @ 1.0	(43 @ .069)	380 @ 4.4	(87.5 @ .30)	580 @ 10	(132 @ .69)
F428-96	1078813	96 (245)	4	250 @ 1.6	(56.8 @ .11)	500 @ 7.4	(113.6 @ .51)	750 @ 16	(170 @ 1.1)
F429-108	1078814	108 (275)	6	315 @ 0.5	(71 @ .034)	635 @ 2.0	(143.6 @ .13)	960 @ 4.5	(218 @ .31)
F429-120	1078815	120 (305)	6	390 @ 0.8	(88.6 @ .055)	780 @ 3.0	(177 @ .20)	1180 @ 7.4	(268 @ .51)
Composite Valves Series K52									
F524-36	1078816	36 (90)	2	35 @ 1.7	(8.0 @ .11)	70 @ 6.8	(16 @ .47)	105 @ 15	(23.8 @ 1.03)
F526-42	1078817	42 (105)	2-1/2	48 @ 0.46	(11 @ .032)	96 @ 2.0	(22 @ .13)	145 @ 4.2	(33 @ .29)
F526-48	1078818	48 (120)	3	62.5 @ 0.8	(14.2 @ .055)	125 @ 3.2	(28.4 @ .22)	190 @ 7.3	(43.2 @ .50)
F526-54	1078819	54 (135)	3	80 @ 1.3	(18.1 @ .09)	160 @ 5.2	(36.2 @ .36)	240 @ 11.5	(54.5 @ .79)
Composite Valves Series K53									
F534-36	1078820	36 (90)	1-1/2	35 @ 1.2	(8 @ .08)	70 @ 4.3	(16 @ .29)	105 @ 9.6	(23.8 @ .66)
F535-42	1078821	42 (105)	2	48 @ 0.6	(11 @ .041)	96 @ 2.7	(22 @ .18)	145 @ 6.0	(33 @ .41)
F535-48	1078822	48 (120)	2	62.5 @ 1.1	(14.2 @ .075)	125 @ 4.5	(28.4 @ .31)	190 @ 10.5	(43.2 @ .72)
F537-54	1078823	54 (135)	3	80 @ 0.4	(18.1 @ .027)	160 @ 1.6	(36.2 @ .11)	240 @ 3.5	(54.5 @ .24)
F537-60	1078829	60 (150)	3	98 @ 0.6	(22.2 @ .041)	195 @ 2.2	(44.3 @ .15)	295 @ 5.4	(67 @ .37)
F537-63	1078824	63 (160)	3	107 @ 0.7	(24 @ .048)	215 @ 2.7	(48 @ .18)	325 @ 7.0	(73.8 @ .48)
SF37-72	1078825	72 (180)	3	140 @ 1.2	(31.8 @ .082)	280 @ 5.0	(63.6 @ .34)	425 @ 11.4	(96.6 @ .78)

Note: Data supplied herein is provided as a guide only. Actual results may vary depending upon actual water conditions and system layout. Flow rates shown are valves only, not completed systems.

Electromechanical Controllers

Description	Part No.
Single Tank, 4 Position Softener	P/N 1078830
Single Tank, 3 Position Filter	P/N 1078831
2 Tank Sequential Filter	P/N 1078832
3 Tank Sequential Filter	P/N 1078833
4 Tank Sequential Filter	P/N 1078834
2 Tank Alternating Softener	P/N 1078835
2 Tank Alternating Softener	P/N 1078836 w/Rinse Down

Electronic Controllers

Description	Part No.
Single Tank, 4 Position Softener	P/N 1078837
Single Tank, 3 Position Filter	P/N 1078838
2 Tank Sequential Filter	P/N 1078839
3 Tank Sequential Filter	P/N 1078840
4 Tank Sequential Filter	P/N 1078841
2 Tank Alternating Softener	P/N 1078842
2 Tank Alternating Softener	P/N 1078843 w/Rinse Down

AquaMatic® Easy Nest Kit

Standard System Layouts

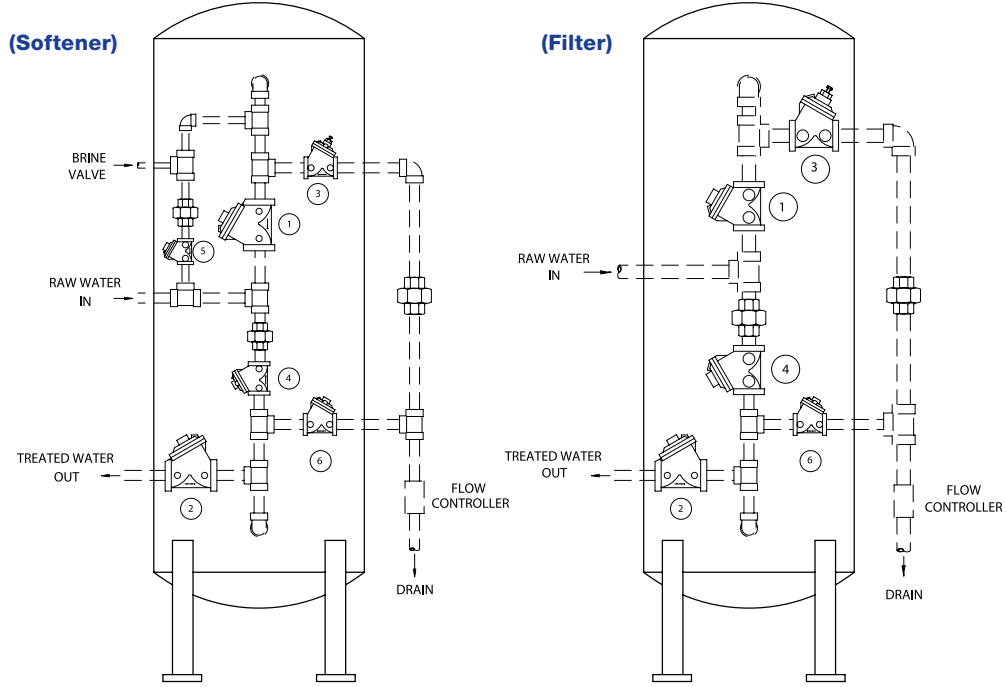

TWO TANK ALTERNATING SOFTENERS

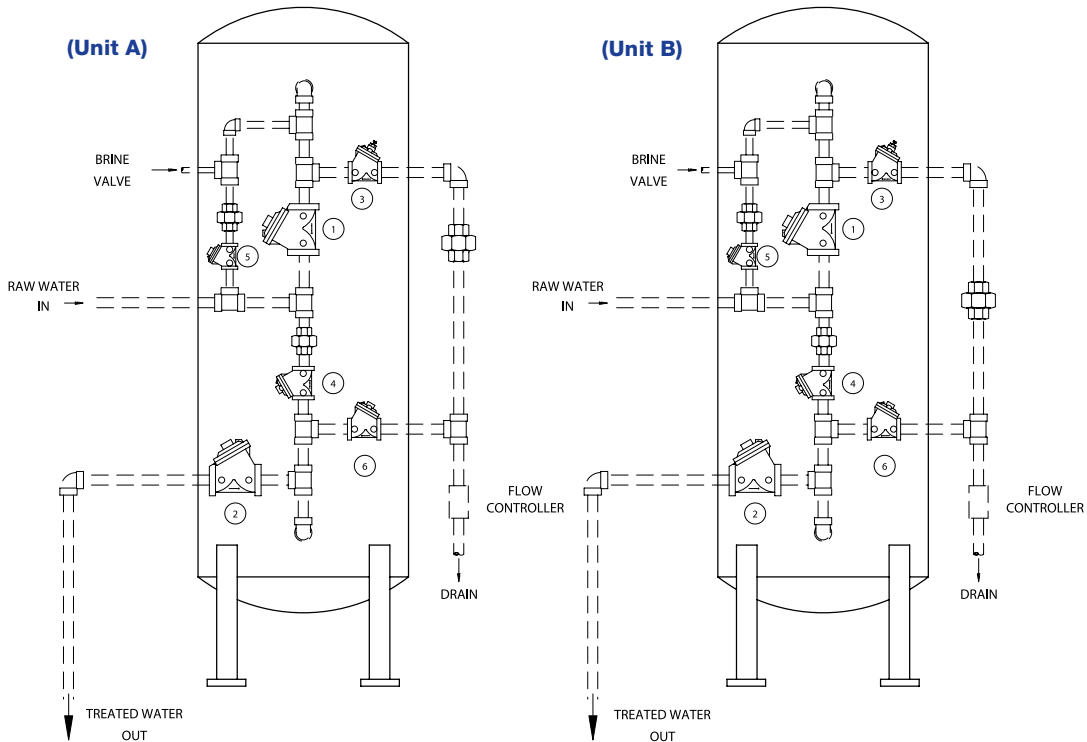

All systems are designed for guideline purposes only. Final authorship of engineering design and application is the responsibility of the assembling OEM. Pentair Water® can not be responsible for the performance and integrity of the installed system.



Standard System Layouts

FOUR TANK SEQUENTIAL FILTER

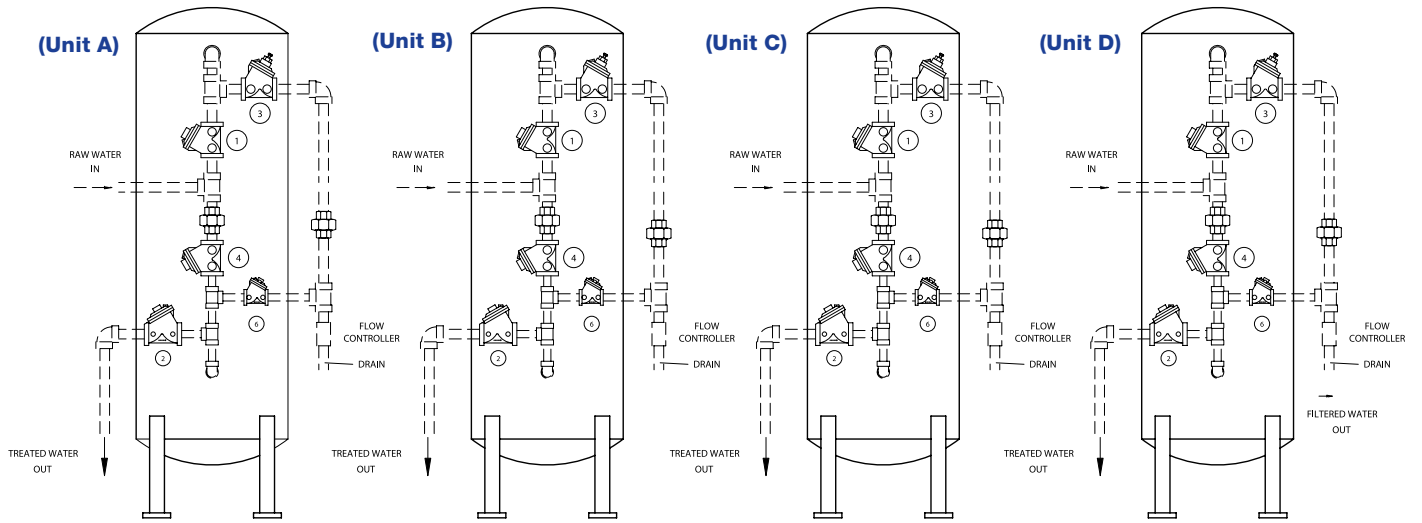

All systems are designed for guideline purposes only. Final authorship of engineering design and application is the responsibility of the assembling OEM. Pentair Water can not be responsible for the performance and integrity of the installed system.



**Pentair
Water**

20580 Enterprise Avenue
Brookfield, WI 53045
Tel: 262.784.4490
Fax: 262.784.7794

5730 North Glen Park Road
Milwaukee, WI 53209
Tel: 262.238.4400
Fax: 262.238.4402

©2010 Pentair Residential Filtration, LLC
1230817 Rev D JA10

Customer Care: 800.279.9404 www.pentairwatertreatment.com