

NORMALLY OPEN

LINE PRESSURE/FLOW AGAINST THE VALVE SEATING DISC WILL OPEN THE VALVE. CONTROL PRESSURE APPLIED TO THE TOP OF THE DIAPHRAGM (PORT "C") WILL CLOSE THE VALVE.

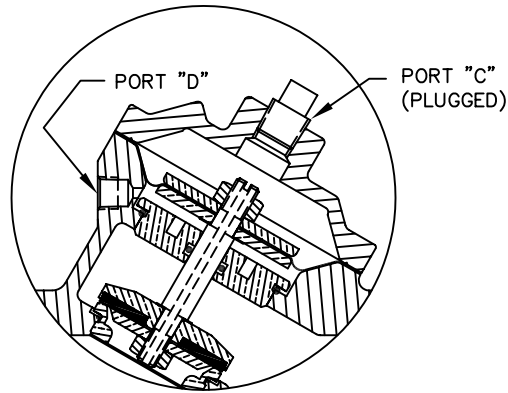

NORMALLY CLOSED

LINE PRESSURE AGAINST THE DISC, TRANSFERRED THRU THE VALVE'S HOLLOW SHAFT TO THE TOP OF THE DIAPHRAGM, WILL CLOSE THE VALVE. CONTROL PRESSURE AT PORT "D" WILL OPEN THE VALVE. ADDITION OF "SPRING ASSIST CLOSED" FEATURE IS RECOMMENDED FOR THE FOLLOWING CONDITIONS:

1. LOW PRESSURE AND/OR FLOW.
2. VALVE DISCHARGES TO ATMOSPHERE.

NORMALLY CLOSED FEATURE NOT RECOMMENDED FOR LINE MEDIA CONTAINING SOLIDS, HIGH TEMPERATURES OR OTHER MEDIA CONDITIONS WHICH MAY DAMAGE THE DIAPHRAGM.

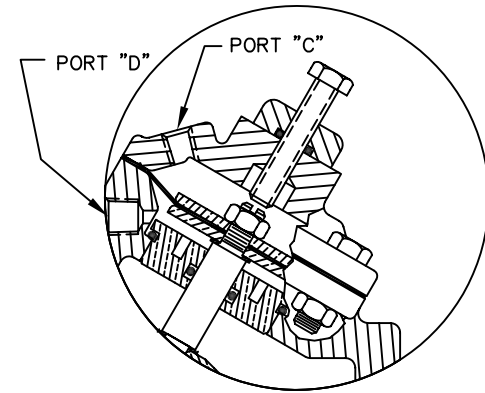

LIMIT STOP

INCLUDES AN ADJUSTMENT SCREW WHICH LIMITS THE VALVE STROKE. MAY BE USED TO CONTROL FLOW RATE, HOWEVER, FLOW RATE WILL VARY WITH CHANGES IN PRESSURE.

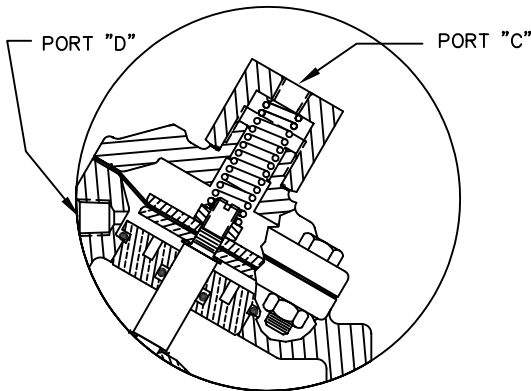

SPRING ASSIST CLOSED

SPRING SERVES AS AN ASSIST TO ASSURE FULL VALVE CLOSURE IN THE ABSENCE OF LINE AND CONTROL PRESSURES.

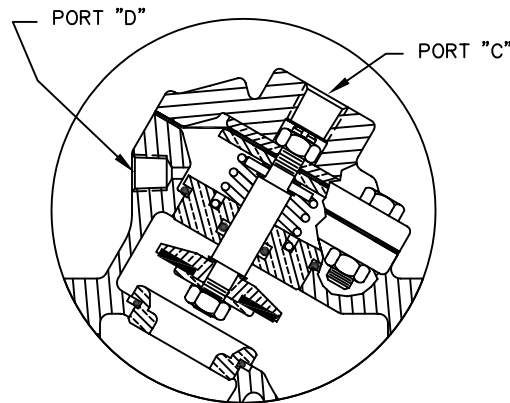

SPRING ASSIST OPEN

SPRING SERVES AS AN ASSIST TO ASSURE FULL VALVE OPENING IN THE ABSENCE OF LINE AND CONTROL PRESSURES.

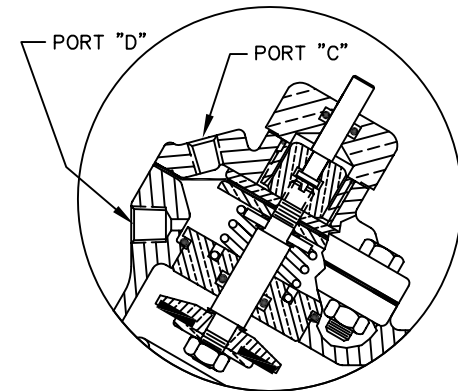

POSITION INDICATOR

INDICATOR ROD IS ATTACHED TO MAIN VALVE STEM TO SHOW POSITION OF VALVE. ONLY AVAILABLE WITH SPRING ASSIST OPEN OPTION.



20580 Enterprise Avenue
 Brookfield, WI 53045
 888.784.9065
 www.Pentairwatertreatment.com

SERIES 420 DIAPHRAGM VALVES

FORM NO. 1078116

B	INITIAL RELEASE	1429	JWB	21JUN01	VKP	SCALE	DRAWN	DATE	DWG. NO.
REV	DESCRIPTION	ECO	DWN	DATE	APVD	N/A	JWB	25APR01	1078117

METAL DIAPHRAGM VALVES (421 THRU 429)

SERIES	PIPE SIZE	SEAT		DIAPHRAGM AREA	TOTAL STROKE	DIAPHRAGM CHAMBER (VOLUME)	* Cv	** Kv	FLOW RATE		PRESSURE DROP	
		DIAMETER	AREA						@ 10 FT./SEC. (3 M./SEC.) NOTE 1	@ 20 FT./SEC. (6 M./SEC.) NOTE 2	@ 10 FT./SEC. (3 M./SEC.) NOTE 1	@ 20 FT./SEC. (6 M./SEC.) NOTE 2
		IN. CM.	SQ. IN. SQ. CM.						GAL./MIN. CU.M/HR	GAL./MIN. CU.M/HR	P.S.I. bar	P.S.I. bar
V42B	3/4"	0.97 2.5	0.74 4.8	2.10 13.0	0.47 1.2	2.06 33.8	11.4	9.8	23 5	46 10	4.1 0.3	16.3 1.12
V42C	1"	0.97 2.5	0.74 4.8	2.10 13.0	0.47 1.2	2.06 33.8	12.8	11.0	23 5	46 10	3.2 0.22	13.0 0.9
V42D	1 1/4"	1.34 3.4	1.41 9.1	6.49 41.9	0.61 1.5	5.20 85.2	26.5	23	44 10	88 20	2.8 0.2	11.0 0.7
V42E	1 1/2"	1.34 3.4	1.41 9.1	6.49 41.9	0.61 1.5	5.20 85.2	32.5	28	44 10	88 20	1.8 0.12	7.3 0.5
V42F	2" (425)	2.02 5.1	3.20 20.6	11.04 71.2	0.70 1.8	10.50 172.1	56	48	100 23	200 46	3.2 0.22	12.7 0.87
V42G	2" (426)	2.31 5.9	4.19 27.0	15.03 97.0	0.99 2.5	16.34 267.8	68	59	130 29	260 58	3.7 0.25	14.7 1.01
V42H	2 1/2"	2.31 5.9	4.19 27.0	15.03 97.0	0.99 2.5	16.34 267.8	84	72	130 29	260 58	2.4 0.16	9.7 0.67
V42J	3"	2.96 7.5	6.88 44.4	22.69 146.4	1.05 2.7	32.80 537.6	134	116	214 49	428 98	2.6 0.18	10.2 0.7
V42K	4"	3.84 9.7	11.58 74.7	33.82 218.2	1.92 4.9	78.83 1292.0	275	238	360 83	720 166	1.7 0.12	6.9 0.47
V42L	6"	6.06 15.4	28.84 186.1	120.28 776.0	1.70 4.3	296.52 4860.0	680	588	899 204	1798 408	1.8 0.12	7.0 0.5

* Cv – FLOWRATE (GAL./MIN.) OF WATER AT 60° F. AT 1 P.S.I. PRESSURE DROP

** Kv – FLOWRATE (CU. M./HR) OF WATER AT 15.5° C. AT 1 BAR PRESSURE DROP

TO DETERMINE FLOWRATE AT ANY GIVEN PRESSURE DROP, THE FOLLOWING FORMULAS CAN BE USED.

FOR WATER AND LIQUIDS:

$$Q = \frac{Cv \sqrt{\Delta P}}{\sqrt{e}}$$

Q – FLOWRATE IN GAL./MIN.
 ΔP – PRESSURE DROP (LB./SQ. IN.)
 e – SPECIFIC GRAVITY (WATER = 1.00)

FOR AIR AND GAS:

WHEN P2 < .5P1 WHEN P2 > .5P1

$$Cv = \frac{CFM \sqrt{e}}{.5P1} \qquad Cv = \frac{CFM \sqrt{e}}{\sqrt{\Delta P P2}}$$

CFM – CU. FT./MIN. FLOW
 e – SPECIFIC GRAVITY (AIR = 1.00)
 P1 – INLET PRESSURE (LB./SQ. IN.)
 P2 – OUTLET PRESSURE (LB./SQ. IN.)

NOTE 1: MAXIMUM CONTINUOUS VELOCITY THROUGH THE VALVE.

NOTE 2: MAXIMUM CONTINUOUS VELOCITY. EXTENDED SERVICE AT THIS VELOCITY MAY CAUSE CAVITATION.

THE DATA PRESENTED HERE IS BELIEVED TO BE RELIABLE AND OFFERED AS SUGGESTION ONLY. ACTUAL RESULTS MAY VARY DEPENDING UPON APPLICATION.

	20580 Enterprise Avenue Brookfield, WI 53045 888.784.9065 www.Pentairwatertreatment.com			
	SERIES 420 DIAPHRAGM VALVES			
FORM NO. 1078116	SCALE N/A	DRAWN JWB	DATE 25APR01	DWG. NO. 1078117

B	INITIAL RELEASE	1429	JWB	21JUN01	VKP	SCALE	DRAWN	DATE	DWG. NO.
REV	DESCRIPTION	ECO	DWN	DATE	APVD	N/A	JWB	25APR01	1078117